

Construction of a Modular Cost Effective Spectrum Analyzer with a Tracking Generator

Building a Foundation for RF Designs, Software, and Tools

Francis Ambion

University of California, Davis
Department of Electrical and Computer Engineering
Davis, CA
fvambion@ucdavis.edu

Abstract— Various modules of a spectrum analyzer with a tracking generator and a vector network analyzer were built based on the open source design of Scotty Sprowls. The purpose for constructing this spectrum analyzer is to provide the Masters student with more depth on knowledge of the tools used in the industry of RF and microwave engineering such as the use of a spectrum analyzer and a vector network analyzer. The components comprising a spectrum analyzer are frequently used in the majority of high frequency design work. The modular design of the spectrum analyzer allows for the use in building the vector network analyzer by rearranging some of the modular circuits and adding several others. The exercise of designing each board gives further hands on understanding of how each device in the system works. The testing procedures for design verification also lead to the experience gained in this project. The circuit design software used was Cadence Allegro. The design and schematic verification software used was Advanced Design System (ADS). The testing equipment used to test each module was the Spectrum Analyzer and Vector Network Analyzer.

Keywords—Spectrum Analyzer; Modular; Tracking Generator; Vector Network Analyzer, Cavity Resonator Filter

I. INTRODUCTION

The overall design for the spectrum analyzer is based off of the open source design by Scotty Sprowls and found on his website [1]. Mr. Sprowls original purpose for designing the spectrum analyzer was to provide a cheaper alternative to buying a commercial spectrum analyzer by building one from scratch himself. His design has evolved to three levels of modular design: a spectrum analyzer, a spectrum analyzer with a tracking generator, and a vector network analyzer. The total cost of these three designs comes in at a sub-\$500 range with a frequency of operation of 0-3GHz. This Masters' Project seeks to complete all analog modules that do not require software. The process flow of this of this project is as follows: a system overview to understand each of the overall purpose of each of the instruments. Then, understand each of the blocks/modules being built. Then, learn Cadence Allegro and build each of the modules with them, keeping in mind RF frequency design by using ADS as verification. The modules are then shipped out to be fabricated through Osh Park and Bay Area Circuits. Each board is assembled and soldered by hand. They are tested in the test bench in Kemper Hall room 3182 using the spectrum analyzer and vector network analyzer available. After passing testing verification to the datasheets and Mr. Sprowls' design

specification of each board, the modules can then be connected and tested together. The final aspect of this project will be interfacing the hardware with the software.

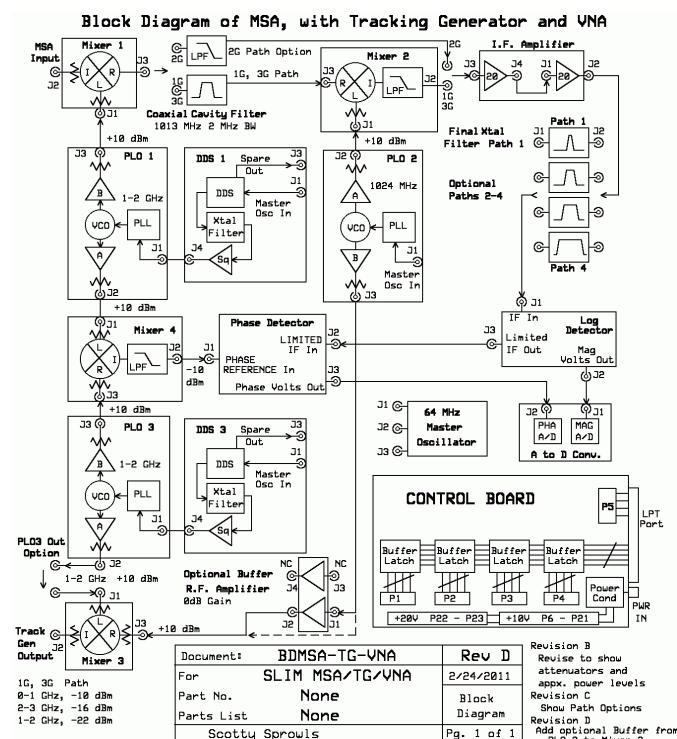

Fig. 1. Block diagram of the Modular Design Spectrum analyzer with Tracking Generator and the Vector Network Analyzer

II. OVERVIEW OF THE DESIGN

Mr. Sprowls' spectrum analyzer design comprises of three main sections: the spectrum analyzer, the tracking generator, and the control portion. Each one of these section is divided up even further into modular components. The modular design of the overall system allows the designer or user to freely change various components of the design for different specifications. Figure 1 shows the overall modular block designs comprising all three of the instruments. The vector network analyzer is also built upon the same modules used in the spectrum analyzer.

A. Spectrum Analyzer

1) The spectrum analyzer's frequency range of operation is 0-1GHz. The sensitivity is 0dBm to -120dBm.

In the provided design, mixer 1 uses the ADE-11x mixer from Analog Devices. It has an LO-RF operating frequency of 10-2000 MHz. There is a 2.5dB attenuator built into the LO input for better matching with the LO input of the IC. The LO input signal is a sweeping signal produced by the PLO 1 board ranging from 950 - 2200MHz. The conversion loss expected for this mixer in the area of operation is about -8dB.

A low pass filter or a band pass filter is next in line after the mixer. The choice of the two types of filters is set by the input frequency of the device. From 0-1GHz and 2-3GHz a narrow coaxial cavity bandpass filter will be used. From 1-2GHz a low pass filter will be used. The input signal will ultimately be filtered and mixed down to a system set Intermediate Frequency of 10.7MHz. The bandpass filter will have a center frequency of 1013.3MHz with a bandwidth of 2MHz or an image rejection of at least 70dB at 1034MHz from the center frequency. This is a very narrow bandwidth, with a fractional bandwidth of 0.2%. Various options to construct this filter were explored varying from SAW filters to LCR filters, but the most practical design to achieve these specifications was to construct a coaxial cavity filter. The coaxial cavity filter needs a very narrow bandwidth to filter out the image frequency created by mixer 1 from entering mixer 2.

The clock of the PLOs frequency sweeps are set by the direct digital synthesizers. The DDS outputs a square wave of 10.7MHz which is set by the master oscillator. The master oscillator sets the clock not only for DDS 1, but for the entire system with a 64MHz square wave at 5Vpp.

After passing through the first filter the input signal will pass through a second mixer, Mixer 2. This mixer has an input local oscillator ranging from 940MHz to 1075MHz, but ideally, a 1024MHz signal at +10dBm input is needed. This frequency input for the local oscillator is from the PLO 2 board, which consists of a passive loop as evidenced by the smaller frequency sweeping range. The frequency can be adjusted slightly so that the output intermediate frequency of Mixer 2 is as close to 10.7MHz as possible. The reasoning for 10.7 MHz as the intermediate frequency is because of the relative ease of designing for 10.7MHz filters and the availability of components at this frequency.

The IF amplifier is a two stage amplifier with a single stage gain of 20dB with a 1 dB compression point output of greater than +13dBm. The use of both stages is not mandatory. The second stage of the IF amplifier is used only if the original RF input signal was weak to begin with and additional gain is needed.

After the IF amplifier, the signal will pass through the resolution bandwidth filter(s). The resolution bandwidth (RBW) determines the fast Fourier transform (FFT) bin size, or the smallest frequency that can be resolved. [...] The smaller RBW has much finer resolution which allows the sidebands to be visible. Finer resolution requires a longer acquisition time. When acquisition time is a factor and the display needs to be updated rapidly or when the modulation

bandwidth is wide, a larger RBW can be used. RBW and acquisition time are inversely proportional. [2]

Scotty Sprowls does not provide a design for a resolution bandwidth filter because it can be left open ended to the user's needs and specifications. He does suggest filters with a center frequency of 10.7MHz with bandwidths of 300Hz, 3 KHz, 30 KHz and 300KHz. For this project a single resolution bandwidth filter was purchased from Digi-Key. It has a center frequency of 10.7MHz and a bandwidth of 15KHz.

The next step is the Log Detector. It is used as a logarithmic detector to convert RF power to DC voltage. This DC voltage is then sent to the A/D converter, which then sends the signal to the latch control where it will interface with the computer software.

In addition, the frequency of the input signal and the frequency of the sweeping PLO 1 that allows the signal to pass through the bandpass filter is kept track of by the PLO 1's connection to the Latch control which is then connected and part of the computer's memory storage. The computer will keep track of the frequency of the input signal by its connection to PLO 1. The input power is ultimately determined by the log detector which samples the signal at the intermediate frequency of 10.7MHz.

B. Tracking Generator

The tracking generator was provided as an add-on to the stand alone spectrum analyzer. The purpose of a tracking generator is to provide a signal to test a particular device's characteristics in a controlled manner.

A spectrum analyzer tracking generator operates by providing a sinusoidal output to the input of the spectrum analyzer. Then, by linking the sweep of the tracking generator to the spectrum analyzer, the output of the tracking generator is on the same frequency as the spectrum analyzer, and the two units track the same frequency. [3]

The spectrum analyzer will then output/display a response to the device being tested from the tracking generator test source.

The modules added to the design of the standalone spectrum analyzer to create the tracking generator are PLO 3, DDS 3 and Mixer 3. PLO3 and DDS3 are identical to PLO1 and DDS1. Mixer 3 is only slightly different from mixer 1. The only differences is the addition of a 14dB attenuator to the RF input of mixer 3 to provide a better impedance match between the RF input connector, J3, and the mixer IC.

The output frequency of the tracking generator will theoretically be identical to that of the sweeping output frequency of PLO 1 going into the LO input of Mixer 1.

C. Control Portion

The control portion consists of three modules: the power conditioner, the voltage converter, and the latch section.

The Power conditioner allows the builder and user to plug in a standard power supply from the wall through a barrel connector. The Power Conditioner accepts 12V to 15V and regulates it to 10V (1A) and to 5V (100 ma max). The section contains pin headers to distribute the 10Vs to user modules or other devices. The voltage converter section accepts 10V and converts it to 20V and -10V. The latch section is the

connection between the entire system and the computer. It is a buffer between the computer and the CMOS data inputs of user modules or other devices. Eight lines of parallel data from the computer (or USB converter) are latched into one of four eight line buffers. Four output signal lines are for sending data back to the computer (or USB converter).

D. Vector Network Analyzer

When implementing the vector network analyzer, only two new modules are needed: Mixer 4 and the phase detector. Most of the other changes for the hardware deal with the additional wiring needed with the latch control to the phase detector to A/D converter, and the latch control to DDS3 and PLO 3. Most everything else is changed from the computer and software components. The vector network analyzer works by having PLO 1 sweep from a frequency of 950-2200MHz to act as the LO for Mixer 1. Controlling this sweep is done through software. Eventually, in sweeping this frequency range, Mixer 1 will shift the input RF frequency to 1013.3MHz. This is the first Intermediate Frequency. The PLO 1 LO input frequency, which mixes the RF frequencies to 1013.3MHz, is kept track of by the computer. PLO 3 tracks with PLO1 but is frequency shifted by 10.7MHz. For example, if the input RF frequency to Mixer 1 is 500MHz, PLO 1 needs 1513.3MHz to get an IF of 1013.3MHz from Mixer 1. So, PLO 2 needs to be 1524MHz. The reason PLO 3 needs to be 10.7MHz difference is because the tracked sweeping frequencies from both PLO 1 and PLO 3 are the input LO and RF inputs to Mixer 4, respectively (the reasoning for this is explained in the next paragraph). The second port of the vector network analyzer uses PLO 3 to output the tracked sweeping range of frequencies. PLO 3's 10.7MHz shifted output frequency (in comparison to PLO 1's output) is shifted in Mixer 3 with the RF input being a constant 1024MHz from PLO 2. This will create exactly the frequency needed to be input to the device, in this example 500MHz, being tested and therefore input into mixer 1.

Mixer 4 must output 10.7MHz because it is used as a phase reference for the Phase Detector. The Phase Detector is a voltage offset phase detector, meaning that it takes two signals of equal frequency and compares the phase between them giving off a range of voltage maximum for being in complete phase or a voltage minimum for being 90 or 270 degrees out of phase. Other variations of phase correspond to voltage values between the minimum and maximum. 10.7MHz is needed for the phase reference because the final IF is 10.7MHz and the phase reference's phase does not change. The phase detector then sends the voltage output to the A/D converter where the software will further analyze the phase for the vector network analyzer.

III. THEORY: THEORETICAL MODULAR BOARD SPECIFICATIONS

Coaxial Cavity Filter:

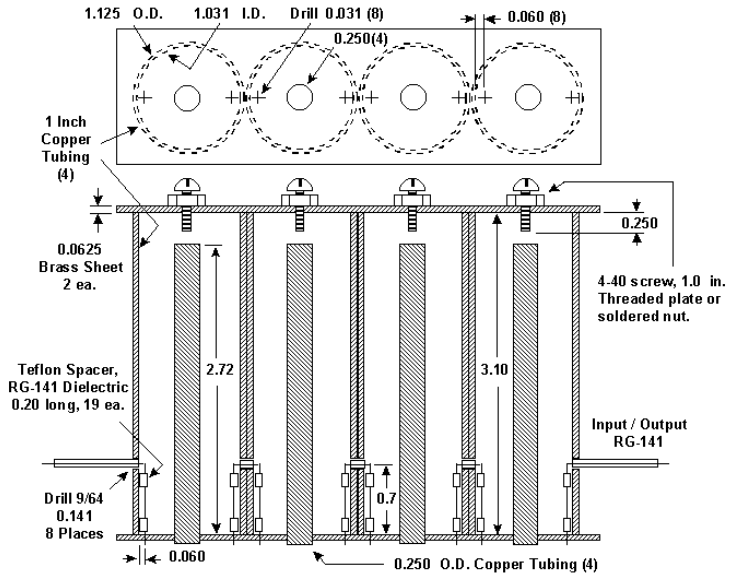

Fig. 2. Physical designed dimensions of the Coaxial Cavity Filter as designed by Scotty Sprowls

This spectrum analyzer was designed to have only two frequency conversions, meaning that it has two intermediate frequencies. This dual conversion scheme minimizes Intermodulation Distortion and Multiple Conversion Harmonic Products. Both are undesirable in a spectrum analyzer. The second I.F. (Final I.F) is set to 10.7MHz. Scotty's reasoning for this is because so many components are commercially available for this "industry standard frequency", more so than any of the other "standards", such as 21MHz, 45 MHz, and 70MHz. With VCO restrictions, and many other factors, this necessitated the first I.F. to be 1013.3 MHz and the second local oscillator to be 1024MHz. As with any receiver, the first I.F. must be the only frequency allowed to enter the second mixer. One signal is most important to keep from entering the second mixer. It is called the image frequency. It is also the most difficult to keep out. The image frequency, when mixed with the local oscillator of the second mixer will create 10.7MHz. This would be 1034.7MHz. (1034.7 - 1024 = 10.7). Image frequencies are created when signals enter the spectrum analyzer (first mixer) and are mixed with the first mixer's local oscillator to create 1034.7MHz. This occurs often, and special attention must be made to prevent the image from reaching the second mixer. In the spectrum analyzer, with the first I.F. at 1013.3 MHz, attenuating the image frequency at 1034.7 MHz is difficult. One of the best ways of doing so was using a very narrow and high Q filter such as a Cavity Resonator Filter. The designed filter is slightly different from that designed from Mr. Sprowls'. This projects cavity filter has adjustable posts and each of the cavities is tunable with a screw added to the top of the cavity.

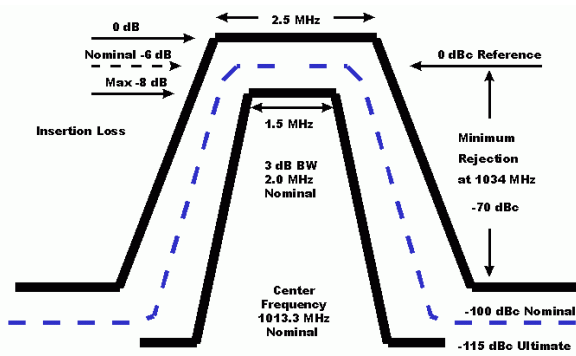

Fig. 3. The Insertion Loss, S21, characteristics and specifications needed for the Coaxial Cavity Filter

The most important specification required for the functionality of the Spectrum Analyzer is for the filter was to have an image frequency rejection of at least -50dB from 1013.3MHz to 1024MHz and an image frequency rejection of at least -70dB from the span of the center frequency of 1013.3MHz to 1034MHz. The Insertion Loss was also expected to have a maximum of -8dB at the center frequency.

Other alternatives to the cavity resonator filter were discussed for this project as well, the main one being a Surface Acoustic Wave (SAW) filter. Although easier to build, the cavity resonator filter was chosen instead because of the potential learning experience gained from building a cavity filter from scratch and the available help and knowledge of other students in the lab and the major professor. Another alternative to building a narrow bandwidth filter would be to add another intermediate frequency into the design of the spectrum analyzer, with three IFs rather than two. However, this would create a need to design another mixer, PLO and DDS, which in itself could be as difficult as building the filter.

A. Miscellaneous Variations to the Modules in the Spectrum Analyzer Design

In addition to the main components on each of the modules, Mr. Sprowls added various filters and attenuators to the mixers and amplifiers. The following results show ADS simulations to verify the designs. These simulations were also used as a learning experience for ADS.

1) Mixer 2

Mixer 2 has a low pass filter at the IF output. It is used to filter out potential high frequency intermodulation products created by the mixer from being amplified by the IF amplifier.

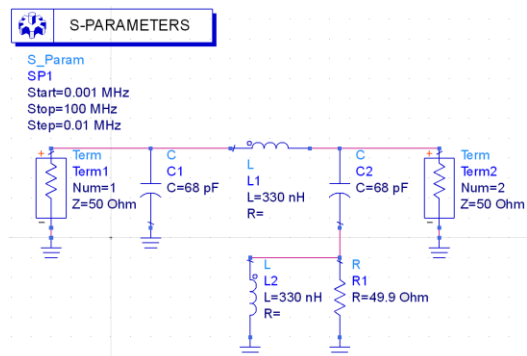

Fig. 4. ADS schematic of the 33MHz low pass filter built into Mixer 2 Low Pass Filter of Mixer 2

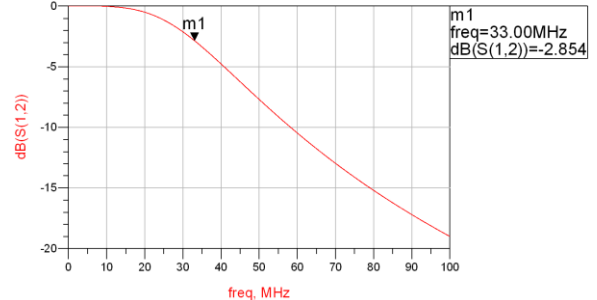

Fig. 5. Insertion loss characteristics of the Low pass filter built into mixer 2

2) IF Amplifier

An ADS simulation was done to verify the circuit components in the IF amplifier design. The design uses as a noise block to protect the amplifier. The source noise is greatly reduced in comparison to not having them at all. This is because of the increased ratio of $1/j\omega c$. The 10uF capacitor takes care of most of the source noise, the 100pf and the 0.01uf capacitors do not provide much function in the high frequency protection but they could be added if a different power source is to be used.

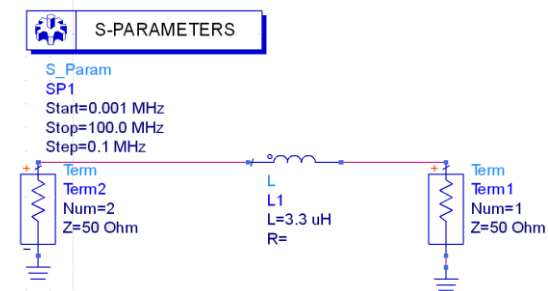

Fig. 6. IF amplifier output schematic without noise block

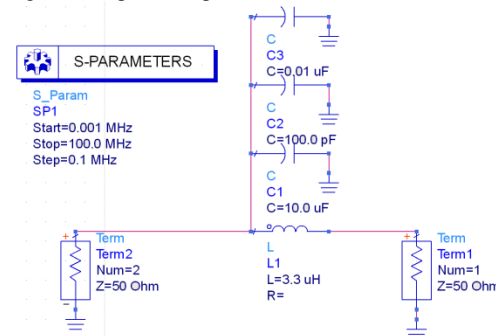

Fig. 7. IF amplifier output schematic with noise block

There are numerous other DC source blocks throughout each of the other modules and designs of the system.

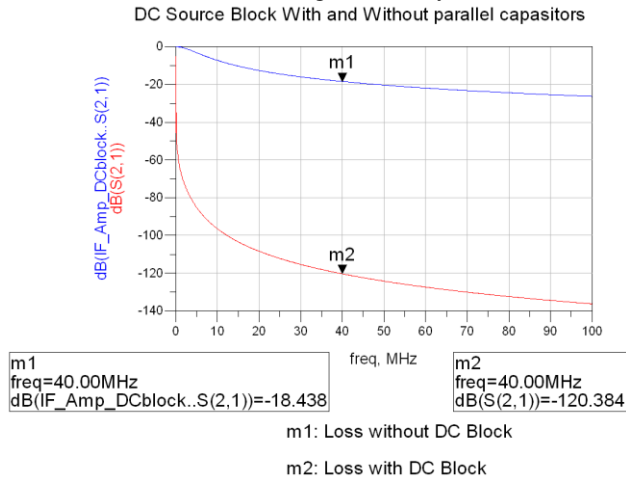

Fig. 8. Return loss characteristics of the IF amplifier output with (Red) and without (Blue) the noise block

There is a 40MHz low pass filter at the end of the amplifier. Its purpose is to filter out nonlinear intermodulation products created by the amplifier.

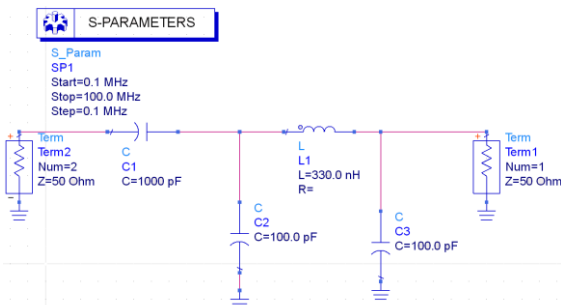

Fig. 9. Low pass filter schematic from the IF amplifier

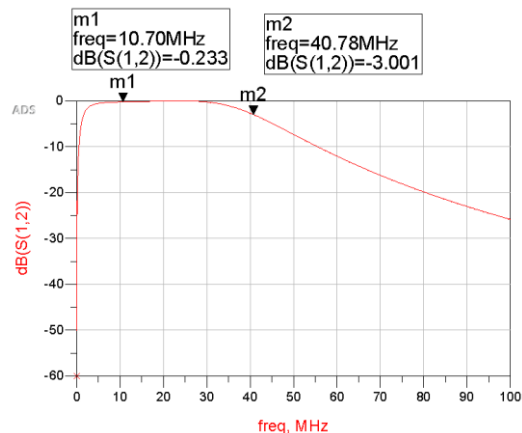

Fig. 10. Insertion loss characteristics of the low pass filter from the IF amplifier

3) Mixer 3

Mixer 3 also has a 14dB attenuator added to the RF input port. The circuit design was simulated in ADS to verify its attenuation.

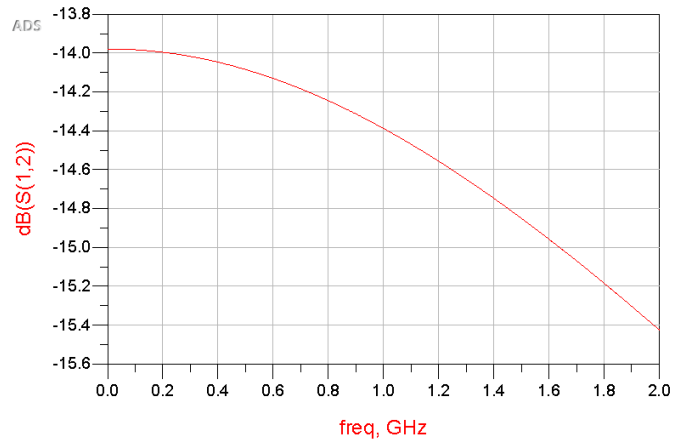

Fig. 11. insertion loss characteristics of the 14dB attenuator at the RF input of mixer 3

4) Master Oscillator

The master oscillator has two inverters that act as a buffer line driver. They are a buffer because the components of the master oscillator are allowed to be separate from the rest of the circuit. The two inverters isolate the master oscillator but offer the same gain. The signal also becomes squarer. The input resistance is very high with the inverters. This leaves the output resistance almost untouched. This condition gives the isolation of the two inverters that creates the buffer effect. Since the input impedance of the inverters is high, the output impedance is untouched and can be matched to the 50 ohm of the rest of the Spectrum Analyzer, more specifically to the direct digital synthesizer that the master oscillator is driving. They are a line driver because the master oscillator drives the direct digital synthesizer.

IV. CONSTRUCTION PROCESS

One of overlying objectives of this project is to build the skills of high frequency design by use of circuit building software, and ADS. Learning Cadence Allegro and its associated software was a big part of the project. Using ADS to verify some of the prepared designs from Mr. Sprowls' website was also used. Most of the designs provided from Mr. Sprowls had to be further verified. When designing and laying out the circuits for each of the modular components two notable differences occurred for these designs because of the higher frequency of operation for some of the components. The first would be the design the traces and spacing of each of the components with each other. The purpose of this is to reduce the loss of the signal mainly due to matching errors (each line was designed for 50 ohm matching) and potential cross coupling errors as well. The particular boards that deal with higher frequencies are the Mixers, PLOs and the Cavity Resonator Filter.

There was a steep learning curve to understanding Cadence Allegro. This involves the digital schematic design to the IC component layout/ PCB design and lastly preparing the files to be fabricated by a manufacturer. The PCBs were

fabricated by Osh Park, with the exception of Mixer 2 which was fabricated by Bay Area Circuits.

Assembling each of the PCB modules and the ICs were not too difficult and most of the issues for their construction involved the accidentally soldering of the SMA connectors to ground and doing step by step verification of each of the components and stages.

Most issues involving the construction phase revolved around the fabrication of the coaxial cavity filter. This was mostly due to the use of a propane blow torch and the transfer of heat affecting and damaging other parts of the cavity. One of the numerous issues was attaching the cavity pipes together by heating them which would then remove the others from the place. This was such a big problem that the design of the four posts was changed to allow it to be adjustable and removable to solder the cavities to the main ground plate. Overall, the change in design worked fantastically in not allowing heat to affect other parts of the system.



Fig. 12. Final construction of the Cavity Resonator Filter with added tuning screws and adjustable poles

V. EXPERIMENTAL MODULAR HARDWARE TESTING AND RESULTS

Spectrum Analyzer

1) Mixer 1

The testing procedure for the mixers involved the use of two function generators and a Spectrum Analyzer.

One function generator acted as a test input for the RF input and the second function generator acted as the Local Oscillator (LO) port. The mixers used are ADE-11X, passive mixers with the driving input at the LO port of 7dBm.

Each mixer was tested differently. They were tested according to their uses and purposes to the overall Spectrum analyzer design as outlined in the previous sections.

Mixer 1 is the input of the spectrum analyzer. The LO Frequency was a sweeping signal from the signal generator ranging from 950-2200MHz at an amplitude of 10dBm. The ultimate goal of mixer 1 is to eventually have the LO

sweeping frequency and the RF input to shift and have an IF output of to 1013.3MHz.

Three input frequencies for the RF were tested: 10MHz, 500MHz, and 1000MHz. These values were chosen because they show the entire range of operation for mixer 1. The ADE-11X mixer has an approximate conversion loss of 7 to 9dB from these ranges.

Plots of Conversion Loss vs. LO Sweeping Frequency were made using the spectrum analyzers MaxHold setting.

RF input 10MHz at 0dBm:

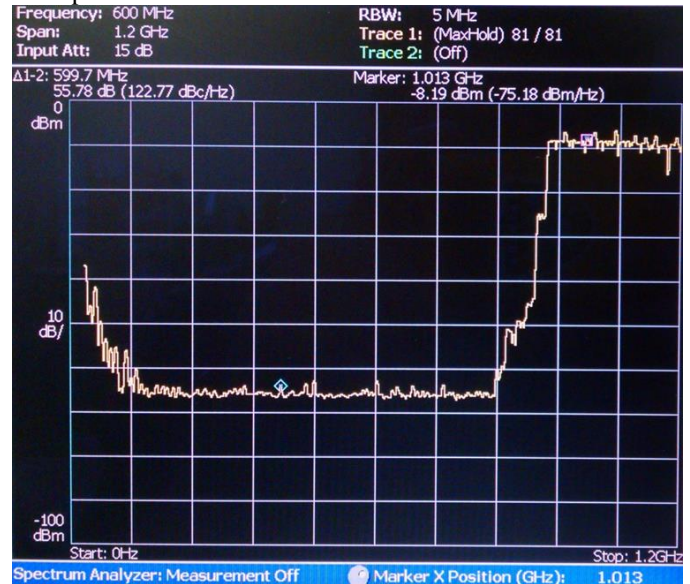

Fig. 13. Mixer 1 IF output: Conversion Loss vs. LO Sweeping Frequency with and RF input of 10MHz at 0dB

This is the expected result of the Mixer output for this range of frequencies. Since the LO sweeps from 950-2200MHz the expected range of valid non attenuated signals for the output of Mixer 1 is 960-2190MHz. However, the Spectrum Analyzer's expected frequency ranges of operation are 0-1GHz. We see that there are no output signals before approximately 950MHz in the CL vs Frequency. Only the necessary range of 0Hz-1.2GHz is shown. Again the approximate value of the conversion loss at 1013.3MHz is reasonable at about -8dBm.

RF input 500MHz at 0dBm:

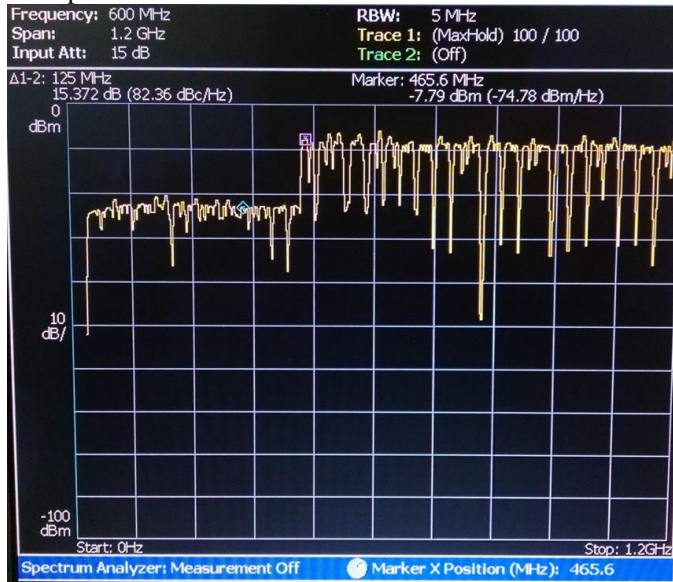

Fig. 14. Mixer 1 IF output: Conversion Loss vs. LO Sweeping Frequency with and RF input of 500MHz at 0dB

This is the expected result of the mixer output for this range of frequencies. Since the LO sweeps from 950-2200MHz the expected range of valid signals for the output of Mixer 1 is 450-2700MHz. Only the necessary range of 0Hz-1.2GHz is shown. Again, the approximate value of the conversion loss at 1013.3MHz is reasonable at about -8dBm.

RF input 1000MHz at 0dBm:

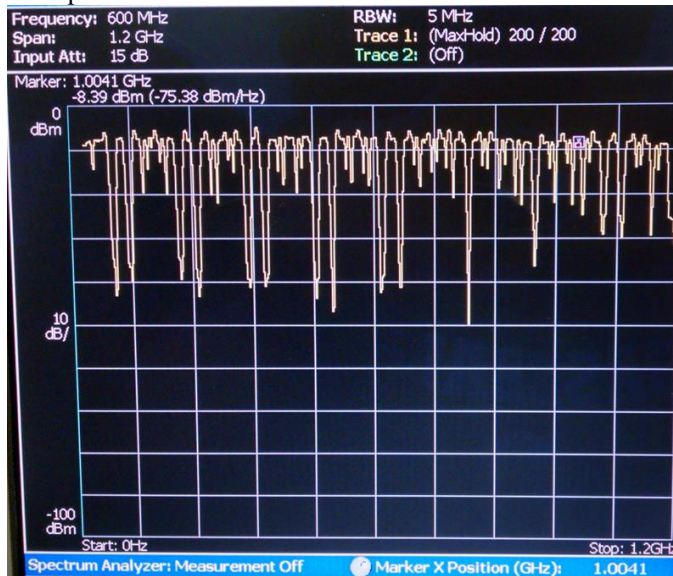

Fig. 15. Mixer 1 IF output: Conversion Loss vs. LO Sweeping Frequency with and RF input of 1000MHz at 0dB

This is the expected result of the Mixer output for this range of frequencies. Since the LO sweeps from 950-2200MHz the expected range of valid signals for the output of Mixer 1 is 50-3200MHz. this spans the necessary range of 0Hz-1.2GHz, which is shown. Again, the approximate value of the conversion loss at 1013.3MHz is reasonable at about -8dBm.

2) Cavity Resonator Filter

The Cavity Resonator Filter was tested on a Network Analyzer. The Insertion Loss, S21, Parameters were measured. The overall results of the designs were well within specification of the designs set by Scotty.

Insertion Loss: S21 (entire span)

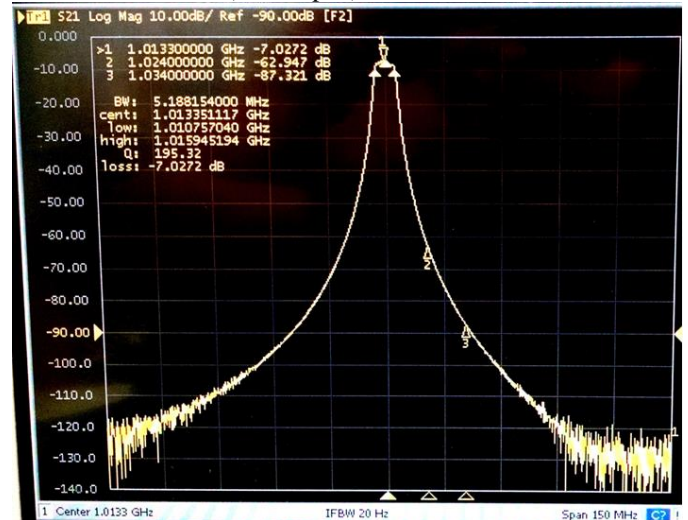

Fig. 16. Insertion loss characteristics, S21, of the Cavity Resonator Filter (wide span)

Most of the Insertion Loss characteristics are within Scotty's specification for the Cavity Resonator Filter.

The maximum allowable insertion loss of the filter is 8dB. The built cavity filter has an insertion loss of -7.0272dB at the center frequency of 1013.3MHz with an input power of 0dBm. This is within the specification of the filter. However, being several dB off from the required insertion loss parameters does not mean that the filter will not work properly because the Intermediate Frequency can and will be amplified later on in the IF amplifier.

The most important specification of the cavity filter is the image frequency rejection at 1024MHz and 1034MHz.

The required rejection from the center frequency of 1013.3MHz to 1024MHz is at least -50dBc. The insertion loss at 1024MHz is -62.947dB from the 0dB reference level. The constructed cavity filter has a rejection of -55.9198dBc from the center frequency. This is within the filter's required specification.

The required rejection from the center frequency of 1013.3MHz to 1034MHz is at least -70dBc. The insertion loss at 1024MHz is -87.321dB from the 0dB reference level. The constructed cavity filter has a rejection of -80.2938dB from the center frequency. This is within the filter's required specification.

The only specification that the constructed filter did not fulfill was the 2MHz bandwidth. The cavity filter has a bandwidth of 5.188154MHz. This specification is not absolutely mandatory to the system. The whole purpose of designing the filter to have such a narrow bandwidth to begin with is so that the image frequency rejection specifications are as high as possible. Since the filter is within specification of both image frequency rejection specifications, it is allowable to have the

bandwidth of the filter wider than what was specified for the design.

Insertion Loss: S21 (Peak)

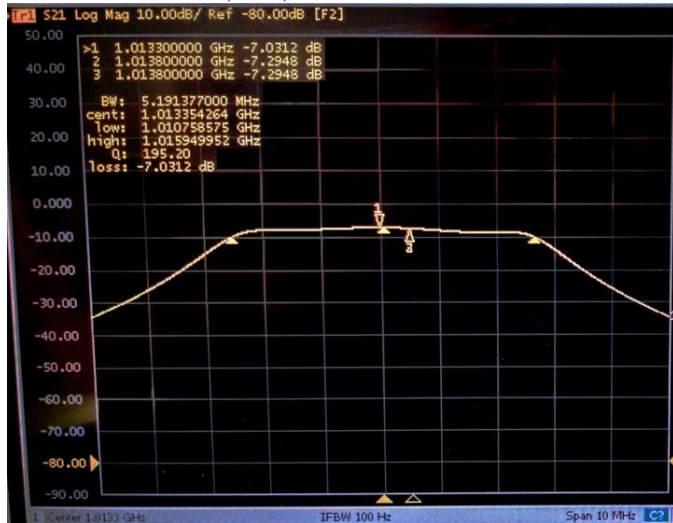

Fig. 17. Closer look at the Insertion loss of the peak of the Bandpass characteristics of the Cavity Resonator filter

Here we see that peak of the filters S21 parameters at the center frequency. Note that there are slight Chebyshev ripples created when tuning each of the cavities of the filter. The rippled flat plateau is the closest convergence possible between each of the 4 peaks corresponding to the tunable response of each of the 4 cavities.

S11: Return Loss

The return loss characteristics were also measured. There is a bit of reflection around the center frequency of the return loss characteristics, but the bandwidth characteristics are reasonable for the purposes of the filter.

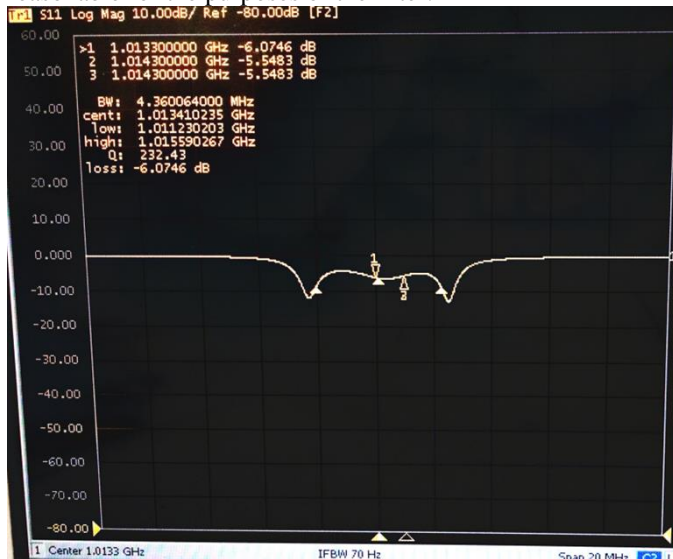

Fig. 18. Return Loss characteristics of the Cavity Resonator Filter

3) Mixer 2

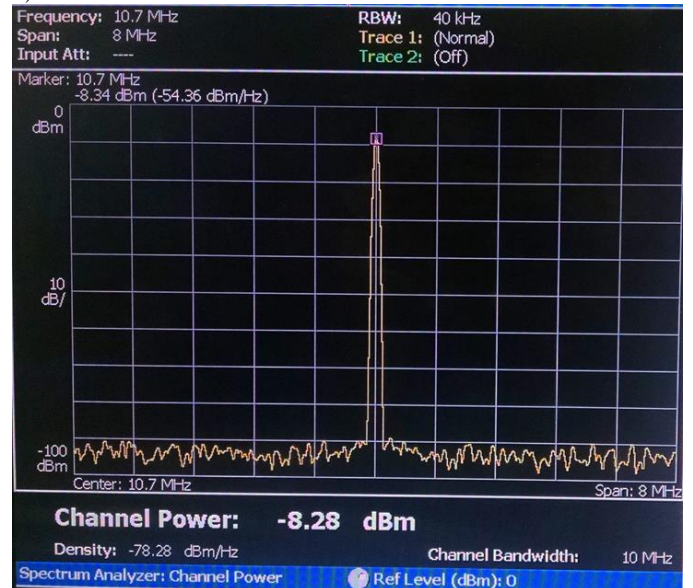

Fig. 19. Mixer 2 IF output: Conversion loss at 10.7MHz with 1013.3MHz as the LO at 0dBm and 1024MHz as the RF inputs at 10dBm.

Mixer 2's use in the system only requires it to have an LO of exactly 1024MHz at 10dBm input power and an RF input of 1013.3MHz coming from the Cavity Resonator Filter. Mixer 2 was tested while inputting these two frequencies using the two signal generators. The RF input was set to 0dBm input power. The expected Intermediate Frequency of 10.7MHz was output by Mixer 2. The conversion loss for Mixer 2 is within the expected loss of approximately 8dB. Other losses in the system could be attributed a 33MHz low pass filter at the output of the mixer's IF port.

4) IF Amplifier

The IF amplifier was tested on a Vector Network Analyzer. The IF amplifier has two stages of amplification, but the second stages is only needed if the input power is very low. It was not possible to test the two amplifiers together because the gain would overload the vector network analyzer. The power setting of the VNA was set to -15dBm, the lowest available power.

The insertion loss, S21, characteristics were measured and were within specification of each single stage amplifier having a gain of 20dB.

The results for each stage are shown below.

Stage 1

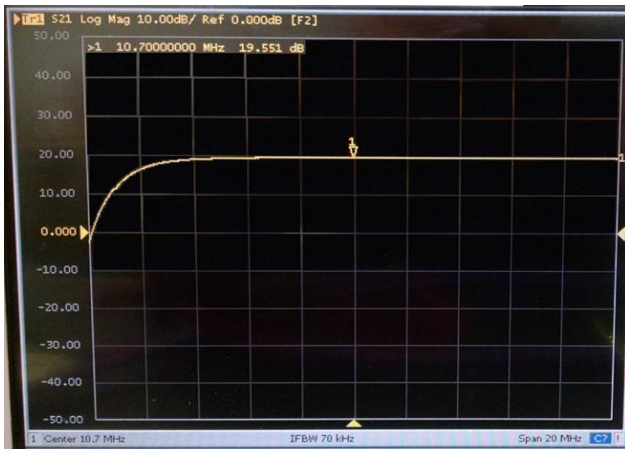

Fig. 20. IF amplifier gain at stage 1

Stage 1 has a gain of 19.551dB

Stage 2

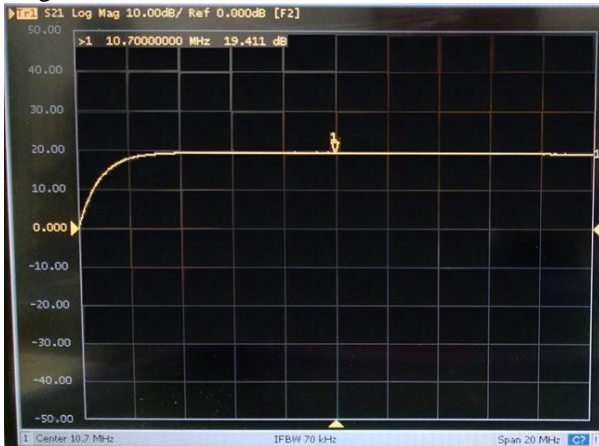

Fig. 21. IF amplifier gain at stage 2

Stage 2 has a gain of 19.411dB

The approximate loss can be attributed to the 33MHz low pass filter at the end of the amplifier.

5) Resolution Bandwidth Filter

The resolution bandwidth filter was tested using the VNA in the lab. The S21, insertion loss characteristics were found.

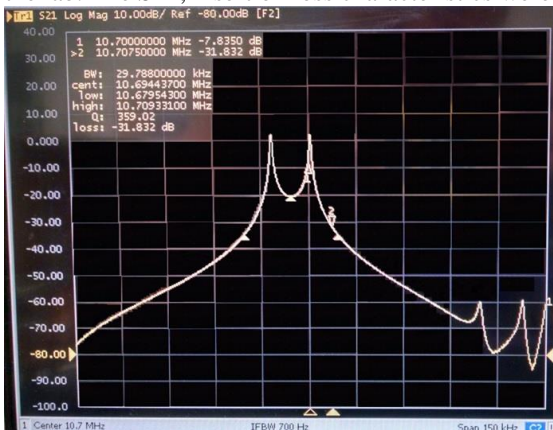

Fig. 22. Insertion loss characteristics of the Resolution bandwidth filter on a Vector Network Analyzer.

The Insertion loss at 10.7MHz is -7.835dB. The bandwidth of the filter is 15KHz so the insertion loss at 10.7125MHz was tested as well. The insertion loss at this point was -31.832db. This shows that there is rejection at the intended bandwidth.

Tracking Generator

1) Master Oscillator

The Master oscillator was tested using an oscilloscope. The power supply voltage was 10V coming from the designed power conditioner. The specifications for the Master oscillator are to have a 64MHz Square wave at 5Vpp for each of the three ports.

Port 1

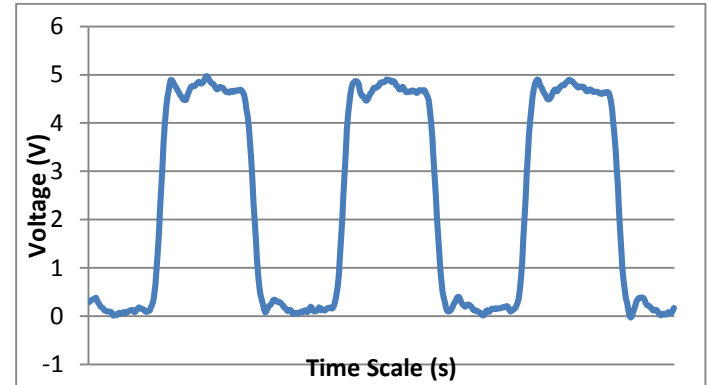

Fig. 23. Master Oscillator output at port 1

Measured Frequency: 64.015MHz

Peak to Peak Voltage (Vpp): 4.95Vpp

Port 2:

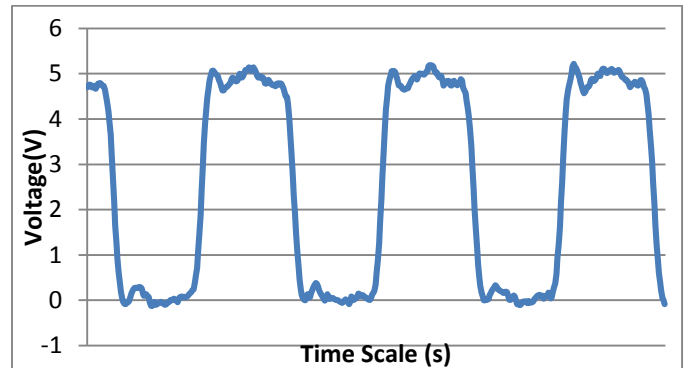

Fig. 24. Master Oscillator output at port 2

Measured Frequency: 64.016MHz

Peak to Peak Voltage (Vpp): 4.99Vpp

Port 3:

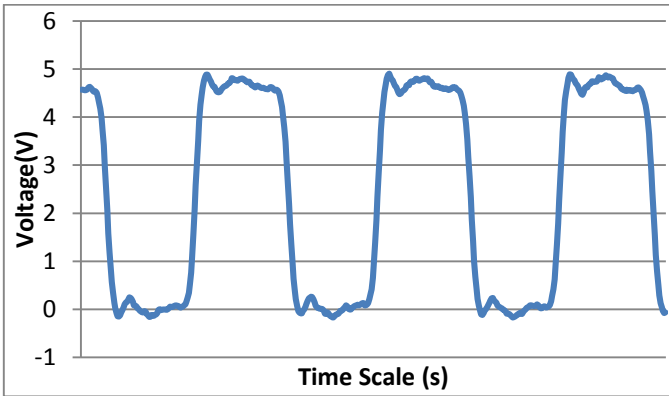

Fig. 25. Master Oscillator output at port 3

Measured Frequency: 64.014MHz
 Peak to Peak Voltage (Vpp): 4.96Vpp

Overall the master oscillator was within specification.

2) Mixer 3

Mixer 3 acts as the output of the tracking generator for the Spectrum Analyzer and Vector Network Analyzer. Mixer 3 was tested using a spectrum analyzer to measure the conversion loss across a range of frequencies and two function generators, one acting as the sweeping LO and the other acting as a static RF input. In the overall system, Mixer 3 will always have an RF input of 1024MHz at 10dBm. One of the function generators was set up to input this signal to the RF port of Mixer 3. The LO will sweep from 950MHz to 2200MHz at 10dBm. The other function generators was set up to input this signal to the LO port of Mixer 3. The spectrum analyzer was set up to read and hold the maximum output values from the IF port of mixer 3 with a span of 0MHz to 1.2MHz. Mixer 3 shows the expected output for this frequency range. The conversion loss of Mixer 3 is as expected as well with a conversion loss of about -8 to -9 dBm over the entire range. This is within range of the conversion loss specified by the data sheet of the ADE-11X mixer. Overall, Mixer 3 works.

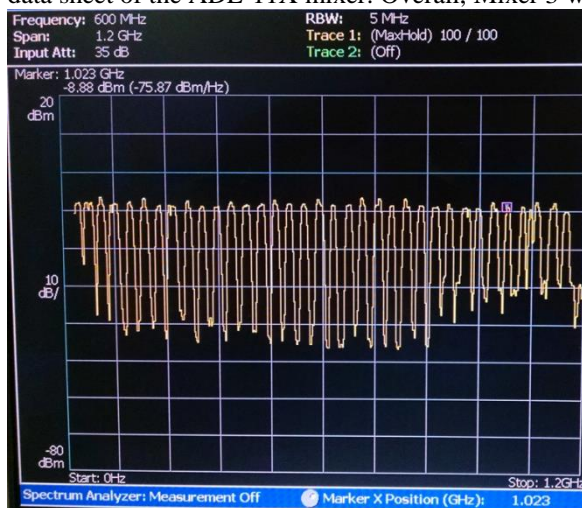

Fig. 26. Mixer 3 IF output: Conversion Loss vs. LO Sweeping Frequency with and RF input of 1024MHz at 10dB

Control Components

1) Voltage Converter

The design specifications of the voltage converter are to take an input of 12 to 15V and output a clean 10V and 5V. With an input of 13V to the voltage converter, an output of 10.00V and 5.00V were measured using a digital multimeter.

Vector Network Analyzer

1) Mixer 4

10MHz Example Test Input:

An input of 1023.3MHz at 10dBm was input into the LO port of mixer 4 using the function generator. An input of 1034MHz at 10dBm was input into the RF port using a function generator. The expected output is 10.7MHz with approximately -10dBm conversion loss. The measured conversion loss was about -10.69dBm.

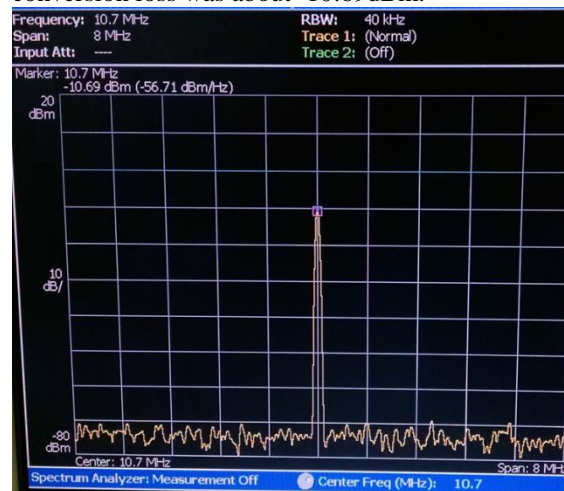

Fig. 27. Mixer 4 IF output: Conversion loss at 10.7MHz with 1023.3MHz as the LO and 1034MHz as the RF inputs both at 10dBm

500MHz Example Test Input:

An input of 1513.3MHz at 10dBm was input into the LO port of mixer 4 using the function generator. An input of 1524MHz at 10dBm was input into the RF port using a function generator. The expected output is 10.7MHz with approximately -10dBm conversion loss. The measured conversion loss was about -11.52dBm. This loss can be attributed to the increase in LO and RF frequencies to the input of the mixers

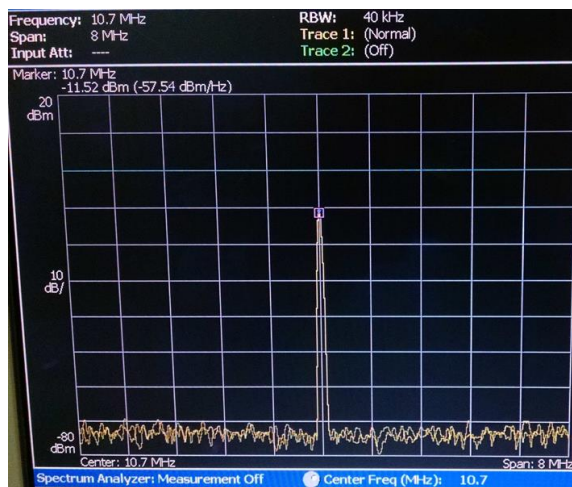

Fig. 28. Mixer 4 IF output: Conversion loss at 10.7MHz with 1513.3MHz as the LO and 1524MHz as the RF inputs both at 10dBm

1000MHz Example Test Input:

An input of 2013.3MHz at 10dBm was input into the LO port of mixer 4 using the function generator. An input of 2024MHz at 10dBm was input into the RF port using a function generator. The expected output is 10.7MHz with approximately -10dBm conversion loss. The measured conversion loss was about -11.85dBm. This loss can be attributed to the increase in LO and RF frequencies to the input of the mixers

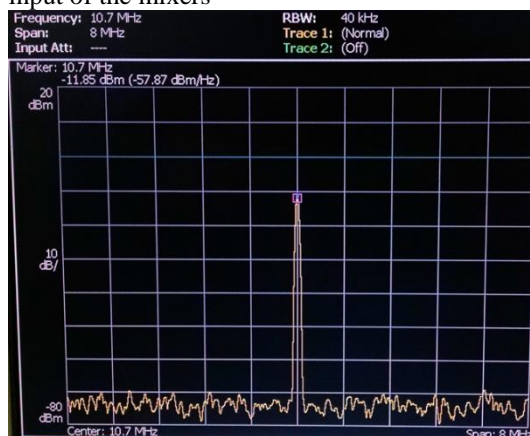

Fig. 29. Mixer 4 IF output: Conversion loss at 10.7MHz with 2013.3MHz as the LO and 2024MHz as the RF inputs both at 10dBm

VI. FUTURE PROSPECTS

The future prospects involving the completion of this spectrum analyzer project involve the construction of the remaining boards. The remaining boards require a computer to interface with and software to control those specific boards. The remaining boards to complete the Spectrum analyzer project are PLO 1, PLO 2, PLO 3, DDS 1, DDS 3, the Log Detector, the Phase Detector and the A/D converter. In addition the Latch portion and Voltage Converter need to be designed. Most of these boards require footprints for several of the ICs. The schematics for the PLOs, DDSs, Log Detector, and the Phase Detector were already built on OrCAD Capture CIS, and are mostly ready to be laid out on PCB Editor for fabrication. Interfacing the components with the software may be one of the more difficult portions of the future prospects of this project. Experience in coding would help with this process.

VII. CONCLUSION

Overall, this project set out to provide the Masters Student with hands on learning experience to RF and Microwave design, construction and measurement/testing. This Masters' Project completed all analog modules of a Spectrum analyzer, Tracking Generator, and Vector Network Analyzer that do not require software. The process flow of this project was to understand the system overview and how each of the blocks/modules being built contributes to the overall system. Then Cadence Allegro was learned and used to build each of the modules, keeping in mind RF frequency design using ADS as verification. The modules were then shipped out to be fabricated through Osh Park and Bay Area Circuits. The Cavity Resonator Filter was also built by hand using store bought materials. Each module was assembled and soldered by hand. They were tested in the test bench in Kemper hall room 3182 using the spectrum analyzer and vector network analyzer available.

ACKNOWLEDGEMENT

Professor Xiaoguang "Leo" Liu, Professor Neville C. Luhmann, Jr., Professor Hooman Rashtian, Professor Omeed Momeni, Professor Diego Yankelevich, Professor Laura Marcu, Professor André Knoesen, Professor G. R. Branner, Akash Anand, Md. Naimul Hasan, Daniel Kuzmenko, James Do, Songjie Bi, Yuhao Liu, Jedediah Roach, Jun Ouyang, Ricky Liu, Negin Kialoni, Ms. Nancy Davis, Reneé Kuehnau, Ms. Kyle Westbrook, and last but not least, Hao Wang.

REFERENCES

- [1] Scotty Sprows' Website for the Spectrum Analyzer Construction <http://scottyspectrumanalyzer.com/msaslim.html>
- [2] Information On the Resolution Bandwidth Filter <http://www.ni.com/white-paper/3983/en/>
- [3] Tracking Generator Basics: http://www.radio-electronics.com/info/t_and_m/spectrum_analyser/analyser-tracking-generator.php
- [4] Phase Detector Data <http://www.markimicrowave.com/blog/2013/05/dc-offset-and-mixers-as-microwave-phase-detectors/>
- [5] Image Frequency Data <http://www.rfcafe.com/references/electrical/image-frequency.htm>
- [6] PLO Information http://www.ece.ucsb.edu/~long/ece594a/PLL_intro_594a_s05.pdf