

Spring Quarter 2014

EEEC193B

Ivan Lee

PCB Tutorial for Eagle

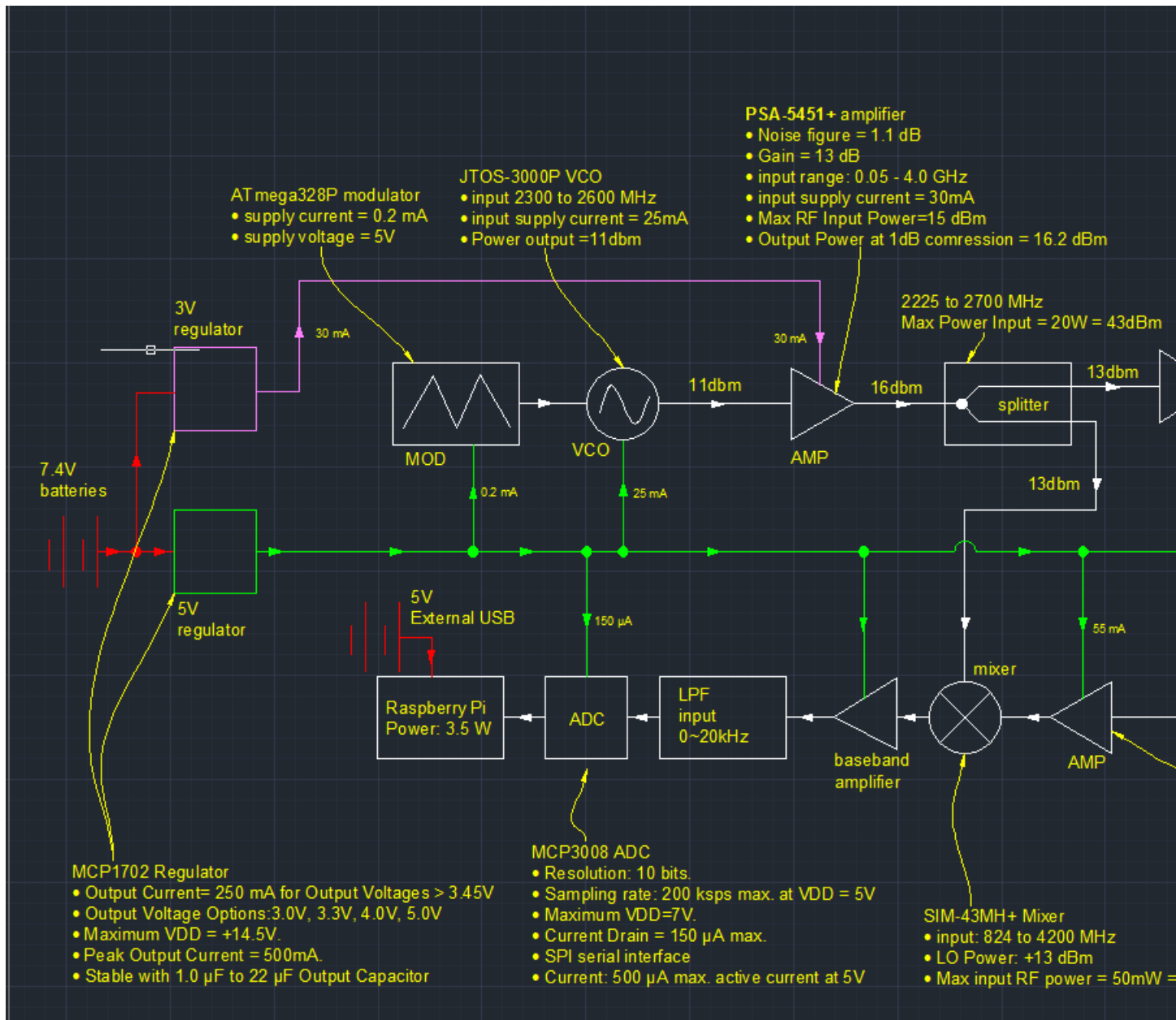

Design Goals

The main goal of this tutorial is to create a compact design of our backup radar shield. This tutorial is focused on designing 4 layers RF PCB board with the FR-4 substrate. Instead of manufacturing two different boards and paying twice, it is a good idea to have two designs on one board because we want to try two different amplifiers with our design.

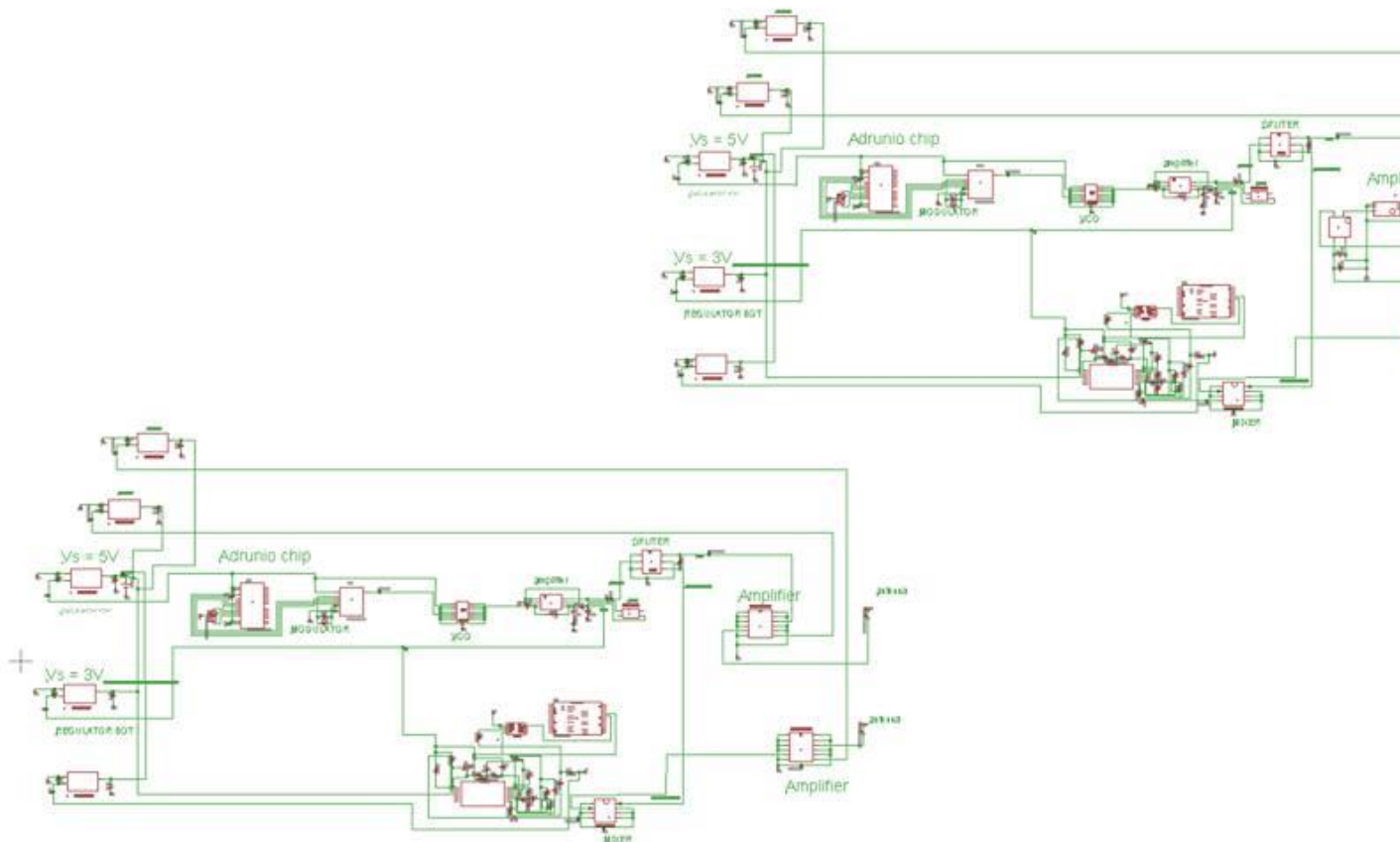

Transmission Wire Width

Before starting out with your PCB, it is a good idea to sort out your RF component because they require the impedance matching of 50ohm. For our design, which is a 4 layer board and $\epsilon_r=4.6$, we find that our width to be 0.352mm. While doing this step, it is also a good idea to find the right manufacture that can deliver the PCB on time and I would recommend Bay Area Circuits because they have student discount for four layer boards for 180\$ and they only require less than one week to complete the PCB. More importantly, if their engineers have any question about your schematic then they will email you and begin production once the issue has been resolved. The location of the factory is in Fremont and if you are willing to drive and pick up the PCB yourself then they are offering to give you a call once the PCB is completed.

4 Layer Foil Lamination - .062				
				Thickness
TOP	L1	Foil	H oz	0.0007
	Prepreg	2116	1	0.0045
	Prepreg	1080	1	0.0030
	L2	Foil	1 oz	
	Core Thickness	0.040		0.0428
	L3	Foil	1 oz	
	Prepreg	1080	1	0.0030
	Prepreg	2116	No. of pcs. 1	0.0045
BOTTOM	L4	Foil	H oz	0.0007
Total Thickness				0.0592

Regulators

It is a good idea to start with the simple component first, for our design, we are using the MCP1702 because creating the design is very simple (only require 2x1uf capacitors), small and it has a lot of different output voltage options. The only down side to these regulators are that they are very small and it is hard to identify the voltage from the regulator if they are misplaced, so label them carefully when they arrived can save time.

- Standard Output Voltage Options:
 - 1.2V, 1.5V, 1.8V, 2.5V, 2.8V, 3.0V, 3.3V, 4.0V, 5.0V
- Output Voltage Range 1.2V to 5.5V in 0.1V Increments (50 mV increments available upon request)
- Stable with 1.0 μF to 22 μF Output Capacitor

Typical Application Circuits

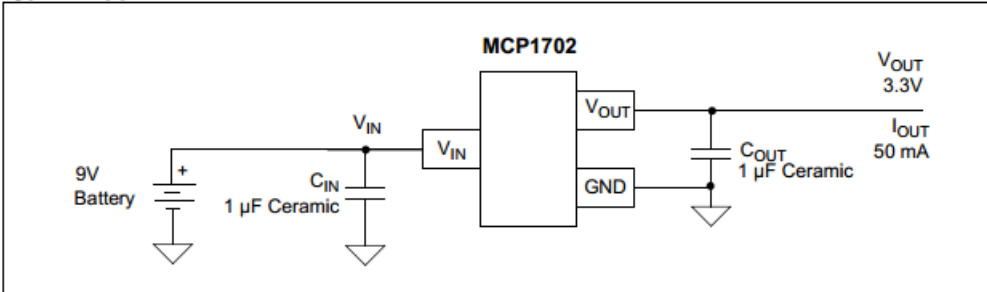

Arduino and Modulator

To create our triangle wave, we uploaded our code onto the Arduino chip, ATMEGA328P and connected to MCP4921. Like quarter1, we make sure that the pins locations from the eagle schematic matches with the schematic of the digital modulator. In order to do that, we have to look at the datasheets of each

component to make sure.

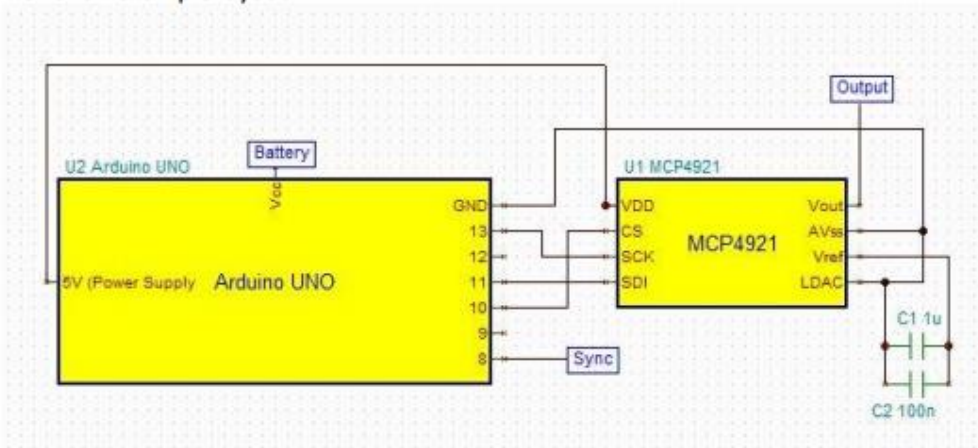

Figure 1.3. Schematic for the digital modulator circuit.

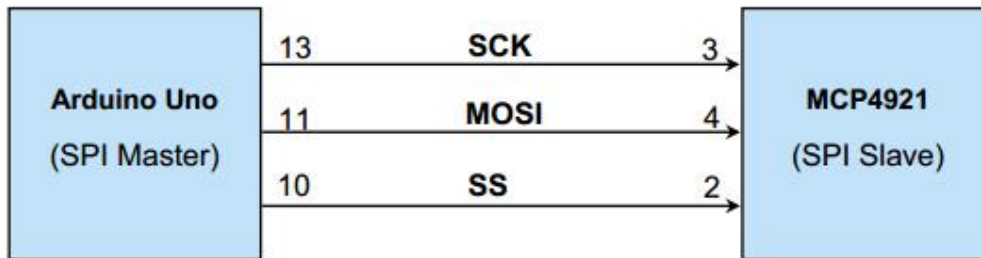
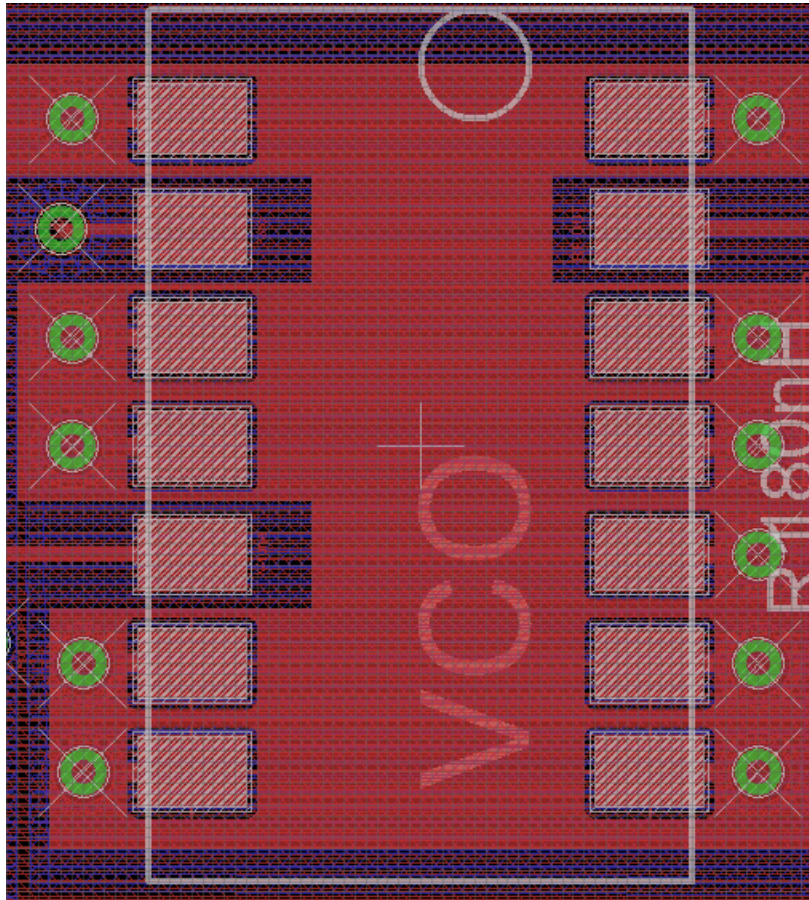
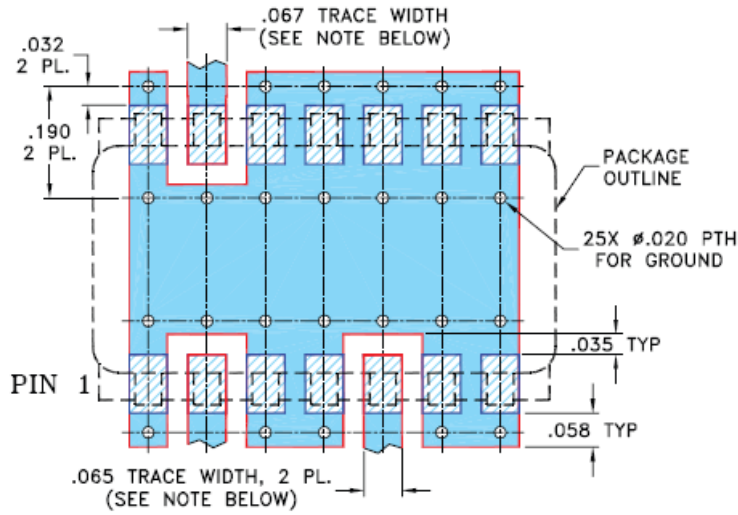

Figure 1.4. The SPI interface.

VCO

For our VCO, we are using JTOS-3000P from Minicircuits. In order to match the recommended circuit, we added polygon named “ground” that matches the recommended PCB circuit on the datasheet.



The polygon on the right side in red is on the first layer of the PCB board and they are all connected to ground, like the preferred PCB layer on left.

For amplifier, we used the TAMP-272+, like our VCO, we have to create a big ground for the component to reduce the noise.

Sending out the PCB

After completing the PCB, we must convert our PCB design into Gerber files for the manufacturer. For our four layer systems, we opened our layout design and we go into CAM processor and start a new job. Instead of manually fill in the layer functions. Eagle has a preset cam file for four layer boards, so we look for the "Open for Job" tab and we select the gerb274x-4layer.cam. We make sure all the layers are correct, for example, for our board, we want to make sure that when the layers are being processing, our top signal layer is with 17 Pad Layer, 18 Vias Layer and 20 Dimension Layer in the .CMP file, etc.

PCB difficulty

When we made our design, we fail to create one of the amplifier (PSA-5451+) because of mismatching. One of the reason would be some of the components within the amplifier are connected with 50 ohms. The solution that we used to solve this problem is by using another packaged (TAMP-272+) and solder the input and output of the older amplifier pads. Surprisingly, the amplifier works, although it is not recommended because it does generate noise to our system.

Another problem that we faced when we received our PCB was that one of the input and output of the mixer are switched. To solve this problem, we tried to add wires to correct this mistake. Unfortunately, one of the input signals is part of RF, so we gain a lot of noise after we wired them. In the end, we notice that the mixer's output is also connected to the ground, so we turned our mixer component (SIM-43MH+) by 45 degree angle and place them on the correct pads, then add extra wire from the ground of the mixer and connect it to our low pass filter.

PCB results

We have completed in turning our design into a compacted form, however, we made a few mistakes that ultimately reduced the effectiveness of the system. However, we only used one try on the PCB and after we have test all of our other components by parts and they all are working properly with some noise introduced into our system. So it is a good idea to keep track of all of our input and output of our RF components because if there is any mistake then the result will have huge amount of loss in the sytem!! So in the end, we can detect about 2 meters of on coming and outgoing object correctly.



Tektronix RSA 3408A Real-Time Spectrum Analyzer



ON / STANDBY



PROPE
Ref.U
Fund

DATE 04 OCT 2012
DUE 04 OCT 2013
TECH 99

This is our return signal using the PCB, it is around -6db

Tektronix

RSA 3408A Real-Time Spectrum A

Tektronix RSA 3408A

6/12/2014 4:52:54 PM UNCAL

Frequency: 2.193613625 GHz
Span: 1.5872375 GHz
Input Att: 25 dB

RBW: 100 kHz
Trace 1: (Normal)
Trace 2: (Off)

$\Delta 1-2$: 944.275 MHz
16.196 dB (66.2 dBc/Hz)

Marker: 2.344269875 GHz
-79.25 dBm (-126.24 dBc/Hz)

10 dBm

10 dB/

-90 dBm

Start: 1.399994875GHz

Stop:

Channel Power: -79.25 dBm

Density: -126.24 dBm/Hz

Channel Bandwidth

Spectrum Analyzer: Channel Power

Ref Level (dBm): 10

ON / STANDBY

TEK - RSA3408A

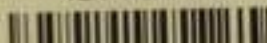

This is the signal that we send out -2db